

## CXM SERIES MICROWAVE COAXIAL SWITCHING SYSTEMS

The CXM Series Systems are computer controlled, passive bi-directional coaxial switching systems designed to handle 50 ohm RF signals from DC to 18 GHz, and in some cases up to 40 GHz. Two basic topologies are offered: Nx1 multiplexers and NxM nonblocking matrices. RS232 & IEEE488 controls are standard, while Ethernet, USB and front panel Manual Controls are optionally available.



CXM/128 Mainframe

### FEATURES:

- RF systems with bandpass from DC to 18 GHz, 50 ohms impedance, low crosstalk & high isolation.
- Some systems with extended bandpass as high as 40 GHz.
- Both Nx1 multiplexers and NxM matrices offered. SMA connectors standard, N, BNC, TNC also available.
- Computer control via IEEE488 & RS232 standard. Ethernet LAN, USB and front panel Manual Controls optional.
- Front Panel LEDs for visual indication of closed switches and remote Status feedback aid in debugging.
- Passive design doesn't add to signal noise or create intermodulation products typical of solid state devices.

### CHASSIS:

The CXM systems are 19" rack mounted chassis, and are built as either Mainframes or Expansion Chassis. They are designed to hold CXM Series Microwave Switches in configurations specified by the user. All chassis have front panel LEDs showing switch point status. RF connectors are typically mounted on the rear panel.

**CXM/16 Chassis** - Furnishes 16 relay drives, allowing two 8x1 switch modules, four 4x1 modules or sixteen 2x1 modules.

**CXM/32 Chassis** - 32 relay drives allow four 8x1 modules, eight 4x1 modules, thirty-two 2x1s, or a combination.

**CXM/64 Chassis** - Up to 64 relay drives. Control up to eight 8x1 modules, sixteen 4x1s, sixty-four 2x1s or a combination.

**CXM/128 Chassis** - Up to 128 relay drives. Control up to sixteen 8x1 modules, thirty-two 4x1s or combinations.

**CXM/256 Chassis** - Up to 256 relay drives. Typically used to control up to 16 CXM/10x1 Switches.

### MICROWAVE SWITCH MODULES:

Several Microwave Switch Module types are offered. Each type has design features tailored to meet specific needs.

**CXM/Nx1-NO Series** are Normally Open type and are available in sizes ranging from 3x1 to 10x1.

**CXM/Nx1-FS Series** are Failsafe type. Similar to the NO type, but these modules default to Port 0 closed when powered off.

**CXM/Nx1-FT Series** terminate unused ports to ground via 50 ohms. Prevents reflections off open ports. 2x1 to 10x1 sizes.

**CXM Transfer Switches** have four ports that switch to one of two configurations. Configuration A routes Ports 1-3 and 2-4. Configuration B routes Ports 1-2 and 3-4.

**Microwave Switches** are available with connectors other than SMAs, higher power ratings and frequencies to 40 GHz. Please contact the Cytec Sales Department for more information.

### CONTROL MODULES:

All systems available with IEEE488 (GPIB)& RS232 (standard), Ethernet LAN, USB or TTL Control.

# CXM CHASSIS

The CXM Series are 19" rack mounting chassis with built in power supplies and are designed to hold the CXM Microwave Switches selected by the user. The switches are typically mounted so that their RF connectors protrude through the rear panel. The front panels have discrete LEDs showing the status of all switch points. The front panels also hold the optional manual controls.

## CXM/16 & 32 MAINFRAME or -E EXPANSION CHASSIS

These Chassis furnish either 16 or 32 switch points in user defined configurations. Built-in front panel LEDs show switch and power status. Add CXM switches along with controls to complete the system.

- Dimensions:** 19" Rack Mount (483 mm)  
15" deep (381 mm)  
3.5" (2 RU) high (89 mm)
- Weight:** 15 lbs (6.8 kg) max.
- AC Power :** 10 W per closed switch- 115/230 VAC selectable.

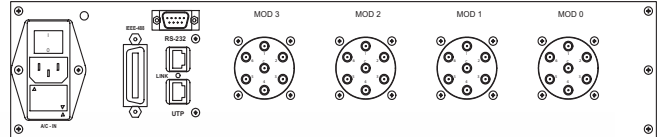

CXM/32 with IEEE488, RS232 and LAN Control

## CXM/64 MAINFRAME OR -E EXPANSION CHASSIS

These Chassis control up to 64 switch points as defined by the user. Front panel LEDs indicate both switch point and power status. Add controls, the required CXM switches and one CL8-VHP Display module for every eight switch points to complete the system.

- Dimensions:** 19" Rack Mount (483 mm)  
15" deep (381 mm)  
5.25" (3 RU) high (133 mm)
- Weight:** 25 lbs (11 kg) max
- AC Power :** 10 W per closed switch- 115/230 VAC selectable

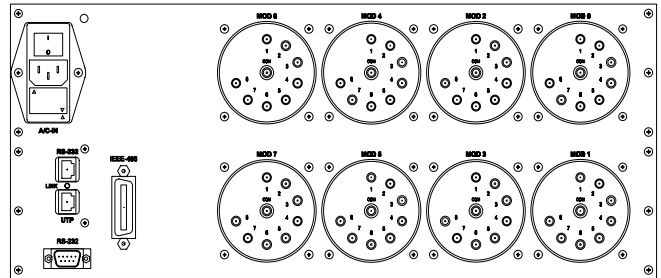

CXM/64 with IEEE488, RS232 & LAN Control

## CXM MATRICES

Bidirectional NxM Matrices are assembled by interconnecti required number of individual microwave switches as shown 1. The matrix is nonblocking, but not full fan-out. Nonbl means that any input can be connected to any output v interrupting a previously set path. When a matrix is not f out, an input may be switched to only one output. Matrix c rations from 2x2 to 8x8 or larger are possible. The switch interconnects are assembled inside the chassis. The inp output connectors (typically SMAs) are mounted on the rear

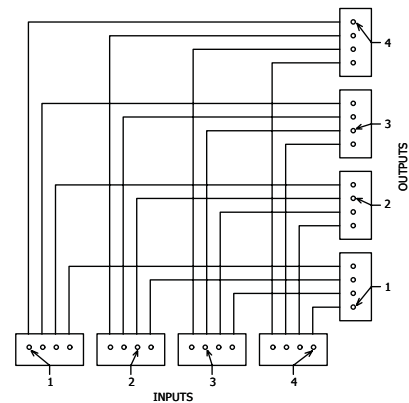

Fig. 1 4x4 Matrix Using Eight CXM/4x1 Switches

**FOR TECHNICAL ASSISTANCE, PLEASE CONTACT CYTEC AT 800-346-3117 OR VISIT OUR WEBSITE AT [cytec-ate.com](http://cytec-ate.com)**

## CXM/128 MAINFRAME OR -E EXPANSION CHASSIS

These Chassis control up to sixteen CXM/8x1 switches arranged as shown on the drawing, or combinations of 1x2, 1x4 and 1x8 switches. LEDs visible through the front panel show switch and power Status. Add CXM switches, controls, and one CL8-VHP Display module for every eight switch points to complete the system.

- Dimensions:** 19" Rack Mount (483 mm)  
 15" deep (381 mm)  
 7" (4 RU) high (178 mm)
- Weight:** 30 lbs (14 kg) max
- AC Power :** 10 W per closed switch- 115/230 VAC selectable

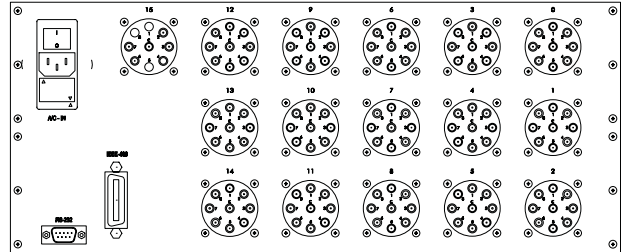

CXM/128 with IEEE488, RS232 and LAN Control

## CXM/256 MAINFRAME OR -E EXPANSION CHASSIS

This Chassis typically controls up to sixteen CXM/10x1 switches, although other configurations are possible. LEDs visible through the front panel show switch and power Status. Add CXM switches, controls and one CL16-VHP Display Module for every 16 switch points to complete the system.

- Dimensions:** 19" Rack Mount (483 mm)  
 15" deep (381 mm)  
 7" (4 RU) high (178 mm)
- Weight:** 35 lbs (16 kg) max
- AC Power :** 10 W per closed switch- 115/230VAC selectable

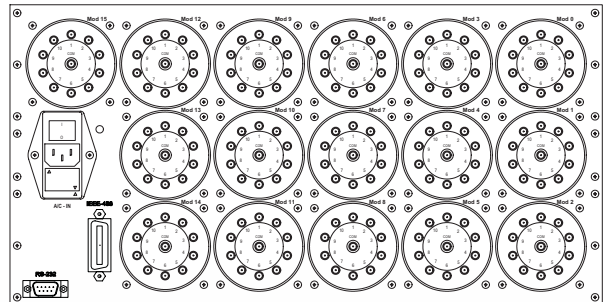

CXM/256 with IEEE-488 & RS232

## CXM MULTIPLEXERS

Nx1 Multiplexers are assembled from standard CXM Chassis by interconnecting microwave switches as shown schematically in **Fig. 2**. The interconnects are typically semirigid coaxial cables and are wired on the rear panel.

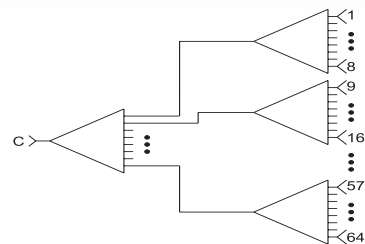

Fig. 2 64x1 Multiplexer using nine CXM/8x1 Switches

**FOR TECHNICAL ASSISTANCE, PLEASE CONTACT CYTEC AT 800-346-3117 OR VISIT OUR WEBSITE AT [cytec-ate.com](http://cytec-ate.com)**

## CXM EXPANSION CHASSIS

All CXM Chassis can be built as either stand-alone mainframes or expansion chassis. Multiple expansion chassis are controlled via a single MESA control chassis. This design allows configuration of large, complex systems with one point of control. Using a MESA controller along with several expansion chassis has the following advantages:

### Cost Savings

Expansion chassis do not require their own control modules or manual controls, which results in cost savings that pay for the MESA on any system using three or more expansion chassis.

### Single Point of Control

Using a single GPIB address, RS232 Port or TCP/IP address, you can control up to 32 CXM chassis, or combinations of different series chassis, from a single MESA.

### Remote Location of Expansion Chassis

Expansion chassis can be located up to 125 feet from the MESA, so the switching chassis can be placed where needed and still not require a dedicated control module.

### Complex Test Systems

Since any Cytec chassis may be controlled from the MESA, you can build complicated systems switching a number of different signal types by using different Cytec products for each signal type. For example, RF signals, AC power, and high speed digital signals could all be switched with a single, multi-chassis system.

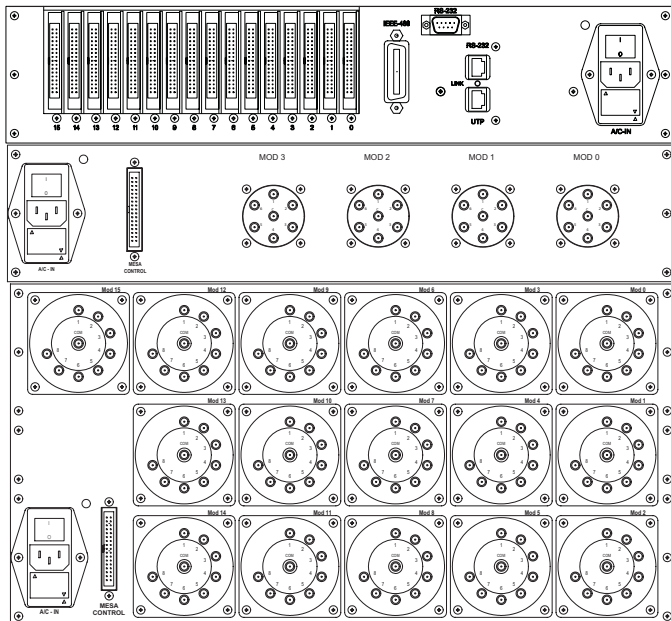

MESA Control Mainframe with CXM/32-E and CXM/128-E Expansion Chassis

## LED INDICATORS / STATUS FEEDBACK

All CXM chassis have front panels LED displays that show the Status of every switch point, which provides an invaluable aid for program debugging and troubleshooting. One LED is assigned to every switch point, and you can verify Status by simply watching the front panel.

### CXM/16 and CXM/32 LED Indicators

LEDs are built into the front panel and are included in the chassis prices.

### CXM/64 and CXM/128 LEDs - CL8-VHP Modules

LEDs are supplied by CL8-VHP Display/Driver Module, each of which provides eight relays drives and status LEDs. These modules must be purchased separately.

### CXM/256 LED Indicators - CL16-VHP Modules

LEDs are built into the CL16-VHP Display/Driver Module, which also supplies 16 relay drives. These are purchased separately.

## CXM CUSTOM CHASSIS

Cytec can usually customize your chassis to meet specific requirements with little or no additional NRE (Non Recurring Engineering) charges. The following examples are only some of the options available. If you don't see what you need feel free to ask us if it can be done. Our engineers will work with you to provide a tailored solution for your specific application.

### Labeling

Cytec's laser etch labeling system allows rapid custom labeling of front or rear panels. Silk screening options or custom poly carbonite overlays are also available for OEM systems.

### Configuration

Cytec can preconfigure your system according to your exact needs. Some examples are:

- Include RF amplifiers to boost signals.
- Built in programmable attenuators reduce signals by a defined amount (1, 2, 4, 8 dB, etc.).
- Splitter/Combiners divide or mix signals as required.
- Directional couplers provide sampling ports.

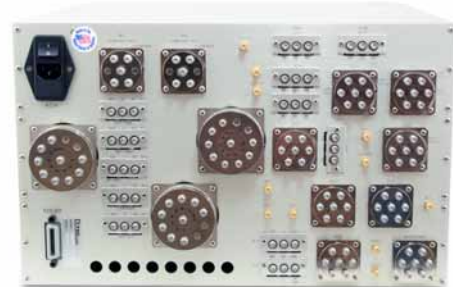

Don't see what you need? Just ask!

**FOR TECHNICAL ASSISTANCE, PLEASE CONTACT CYTEC AT 800-346-3117 OR VISIT OUR WEBSITE AT [cytec-ate.com](http://cytec-ate.com)**

# CXM COAXIAL MICROWAVE SWITCHES

Standard CXM Switches are 50 ohm, bi-directional, failsafe, Normally Open switches with a bandpass of DC to 18 GHz. Configurations from 1x2 to 1x10 are available, and SMA connectors are standard.

**OPTIONAL FEATURES INCLUDE:** Failsafe default to Port 0 closed, latching actuators, BNC, TNC or N Connectors, unused input ports terminated to 50 ohms and higher frequency or power handling capacity. All options are not available on all models; contact one of our expert Sales Engineers for more information.

## CXM/2x1-F (Form C )

Is a SPDT microwave switch that defaults to its NC position. Options include connector type, higher RF power handling ability, unused port termination and latching actuators.



## CXM/4X1-NO SWITCH

Is a Single Pole 4 -Throw Normally Open microwave switch. Options include connector type, higher RF power, latching actuators, failsafe operation, terminations and frequencies to 40 GHz.



## CXM/6X1-NO SWITCH

Same as the CXM/4x1, but in a SP6T configuration. The same options are available.

## CXM/8X1-NO & CXM/10X1-NO SWITCH MODULES

Are SP8T and SP10T configurations. Different connectors are optionally available.

## CXM TRANSFER SWITCH

Transfer Switches have four ports and two switch positions. Position 1 connects Ports J1 to J4 and J2 to J3. Position 2 connects J1 to J2 and Ports J3 to J4. Options include different connectors and frequencies to 40 GHz. See Fig. 3.

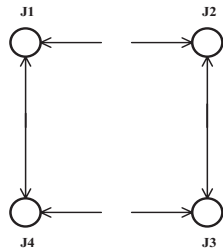

Fig. 3 CXM Transfer Switch

## SWITCH MODULES SPECIFICATIONS

Microwave Switch specifications vary depending on the options selected. The following are typical:

	1 GHz	18 GHz
Insertion Loss	0.3 dB	0.8 dB
Isolation	-80 dB	-60 dB
VSWR	<1.2:1	<1.5:1
Switching Time	<15 ms	<15 ms
RF Power, SMAs *	150 W	40 W
RF Power, Type N **	300 W	90 W at 14 GHz

### Notes:

- \* RF Power is CW cold switching at frequency indicated.
- \*\* Type N Connectors rated to 12 GHz only.

Specifications are for switches only. Cabling or connector options may decrease some ratings. Call for specifications on assembled systems.

## CXM TERMINATED SWITCHES

Self-terminating Microwave Switches connect all unused input ports to ground via 50 ohm terminations. Available with all multiposition switches from CXM/2x1-T to CXM/10-T. Terminations can handle 2 watts CW. See Fig. 4 for a schematic of a terminated CXM/2x1-T.

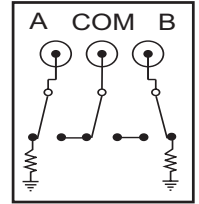

Fig. 4 CXM/2x1-T Terminated Switch

## CXM/2X1-T-SMA (TERMINATED)

Is a SPDT Microwave Switch with both inputs terminated to 50 ohms when not switched. See Fig. 4. Options include latching actuators and frequencies to 26.5 GHz.

## CXM/4X1-T-SMA & CXM/6X1-T

Are Single Pole 4 Throw and SP6T with non-switched inputs terminated to 50 ohms. Options include latching actuators and frequencies to 40 GHz.

## CXM/8X1-T-SMA & CXM/10X1-T

Are SP8T and SP10T with non-switched inputs terminated to 50 ohms as shown in Fig. 5. Options include latching actuators and frequencies to 40 GHz.

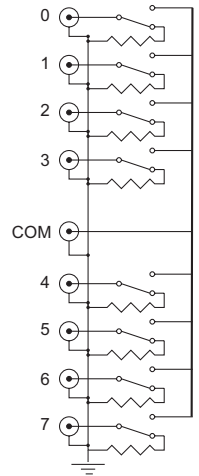

Fig. 5 CXM/8x1-T Terminated Switch

## CONNECTOR OPTIONS

SMA Connectors are standard on all Microwave Switches rated up to 26 GHz. Optional connectors include **K Type** rated at DC to 40 GHz and **N** or **TNC** rated for higher power but lower frequency applications. Not all connectors are available on all switch types; for example, Terminated Switches are only built with SMA or K Type. Please contact the factory for more information.

## LATCHING or FAILSAFE ACTUATORS

Microwave Switches with optional **Latching Actuators** remain in their current switched positions until switched by the user to another position, even if power is removed. Switches with optional **Failsafe Actuators** return to Port 0 closed when power is removed.

**DON'T SEE WHAT YOU NEED?  
PLEASE CALL FOR MORE OPTIONS**

# PROGRAMMABLE ATTENUATORS, SPLITTER/COMBINERS

On a semi-custom basis RF devices such as Programmable Attenuators, Splitter/Combiners and Directional Couplers can be installed inside your CXM Chassis to furnish a complete, turn-key test setup.

## PROGRAMMABLE ATTENUATORS

Relay based and solid state attenuators are available in a variety of step sizes (such as 1 dB, 2 dB, 4 dB, 8 dB, etc.) and frequency ranges. Step size control is via Cytec's standard, simple programming commands. Including attenuators as part of the switching systems permits the end user to consistently, repeatable program precise signal attenuation steps. See Fig. 6.

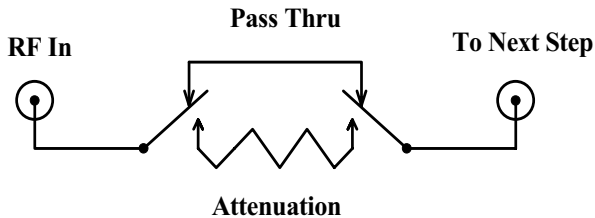

Fig. 6 Relay-based Programmable Attenuator

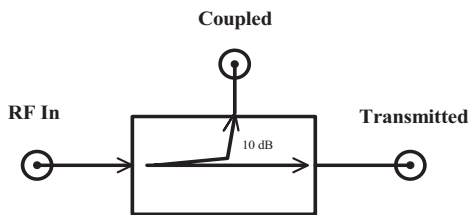

Fig. 8 Directional Coupler -10 dB

## CYTEC SWITCH MANAGER SOFTWARE

The Cytec Switch Manager provides a GUI interface for remotely controlling both matrices and multiplexers. The software includes an intuitive graphical interface, security implementation, built in test functionality, multiple device control, switchpoint memory, as well as many other useful features. You can download the Switch Manager free of charge from our website.

Available for Windows, Linux, Mac OS, or any other Java enabled platform

## SOFTWARE

Free drivers and/or sample programs are available for most commonly available application programming languages.

## WARRANTY

All CXM Series Microwave Relays include a full one year warranty. All other system components include five year warranties.

## POWER DIVIDERS/COMBINERS

Are passive devices that offer high directivity and good port to port matching. 2 - way, 4 - way, 8 - way and 16 - way Power Dividers/Combiners can be included as part of your microwave system. Inductive and Resistive Dividers are offered that have low insertion losses and VSWRs and frequencies as high as 18 GHz. Contact factory for more information. See Fig. 7.

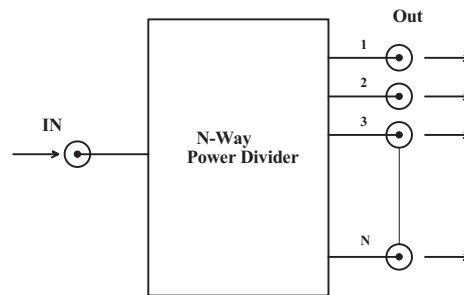

Fig. 7 1 : N Power Divider/Coupler

## DIRECTIONAL COUPLERS

A Directional Coupler has three ports: input, transmitted and coupled. It couples part of the transmission power to the coupled port by a known amount, typically -10 dB, -20 dB or -30 dB. The coupled output can be used to measure information (for example, power level and frequency) without interrupting the main RF power flow. See Fig.8.

## CONTROL MODULES

### IF-5C IEEE488/RS232 16 and 32 Channel Control

This Module has both the IEEE488 (Talk/Listen) and the RS232 features detailed in Applications Bulletin AP-5. This combination module is used on all CXM/16 or CXM/32 chassis.

### IF-5 IEEE488/RS232 64 and 128 Channel Control

This Module has both the IEEE488 (Talk/Listen) and the RS232 features detailed in Applications Bulletin AP-5. This combination module is used on all CXM/64, CXM/128 or CXM/256 chassis.

### IF-6 LAN INTERFACE

This Module uses Ethernet TCP/IP to provide control from a Local Area Network as described in bulletin AP-5. It is available as an option on any mainframe chassis.

### MANUAL CONTROL OPTION

Manual Controls are available for all mainframe chassis.

CXM/16 and CXM/32 chassis can be purchased with optional pushbutton manual controls PB/16 or PB/32.

CXM/64, CXM/128 and CXM/256 mainframes can be built with optional keypad manual controls MC-2.

**FOR TECHNICAL ASSISTANCE, PLEASE CONTACT CYTEC AT 800-346-3117 OR VISIT OUR WEBSITE AT [cytec-ate.com](http://cytec-ate.com)**