

## CXAR SERIES COAXIAL SWITCHING SYSTEMS

The CXAR Series are Computer Controlled Coaxial Switching Systems for 50 or 75 ohm RF Signals up to 1.6 GHz, or Low Leakage signals down to 100 Femto amps. These systems are typically used to configure 1xN multiplexers. Both Mainframes and Expansion Chassis are offered and hold a variety of different switch modules to form the desired configuration.

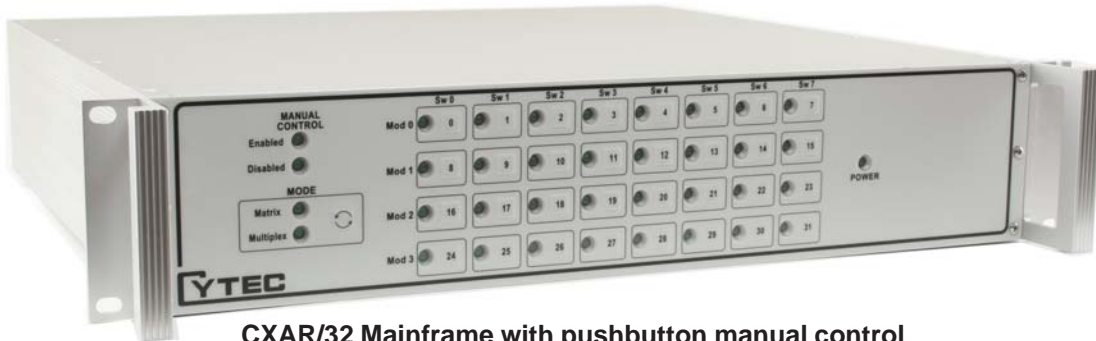

CXAR/32 Mainframe with pushbutton manual control

### FEATURES:

- RF Systems with Bandpass from DC to 1.6 GHz, 50 or 75 Ohm Impedance and low crosstalk.
- Low Leakage modules for current measurements down to 100 femto amps or resistance up to 100 terra ohms.
- Low cost reed relay 1 or 2 pole coaxial modules for high speed, long life switching of signals below 100 MHz.
- Computer Control from IEEE488 BUS, RS232 Serial, 10BaseT LAN, TTL or USB.
- LED Front Panel Display and Status Feedback to Computer for visual indication and debugging.
- Manual Control Option for use without computer control.

### CHASSIS:

The CXAR Units are 19" rack mounted chassis, and are available as either Mainframes or Expansion Chassis pre-wired to accept any of the CXR Series of Coaxial Switch Modules. All chassis have front panel LEDs showing latched switch points and have I/O connectors mounted through the rear panel.

**CXAR/16 Mainframe or -E Expansion Chassis** - 16 relay drives allow for two 8x1 modules or four 4x1 modules.

**CXAR/32 Mainframe or -E Expansion Chassis** - 32 relay drives for four 8x1 modules, eight 4x1 modules or combinations.

**CXAR/64 Mainframe or -E Expansion Chassis** - Up to 64 relay drives. Control up to 16 4x1 modules in a 5.25" high chassis.

**CXAR/128 Mainframe or -E Expansion Chassis** - Up to 128 relay drives. Control up to 16 8x1 modules or 8 16x1 modules in a 7" high chassis.

### SWITCH MODULES:

There are five series of Switch Modules. Each series has design features tailored to specific needs.

**CXR Series** use coaxial reed relays and are available with a bandpass up to 200 MHz. BNC or Screw Terminal Connectors.

**CXR-G Series** use armature relays in a tree configuration and have a bandpass exceeding 1 GHz. BNC or SMA Connectors.

**CXR-2A Series** use two pole relays to switch balanced line signals and have bandpass up to 200 MHz. BNC's or Twin-ax.

**CXR-LL Series** use single pole low leakage relays for currents as low as femto amps or resistance as high as terra ohms.

**CXS Series** use solid state relays for high reliability 50 or 75 ohm switching.

### CONTROL MODULES:

All systems available with IEEE488 (GPIB), RS232, Ethernet LAN, TTL or USB Control.

# CXAR CHASSIS

The CXAR Chassis are 19" rack mounting units with power supplies and are pre-wired to accept the CXR Series of Switch Modules. The Switch Modules are mounted so that their I/O connectors protrude through the rear panel. The front panels have discrete LEDs showing the status of all switch points and also provide optional manual controls.

## CXAR/16 MAINFRAME OR -E EXPANSION CHASSIS

These Chassis control up to 16 switch points in any configuration. LEDs on the front panel show switch and power status. Add Switch Module(s) and a Control Module to complete the system.

- Dimensions:** 19" Rack Mount (483 mm)  
 15" deep (381 mm)  
 3.5" (2 RU) high (89 mm)
- Weight:** 15 lbs (6.8 Kg) max
- AC Power :** 10 Watts max. 110/220 selectable.



CXAR/16 With Pushbutton Manual Control

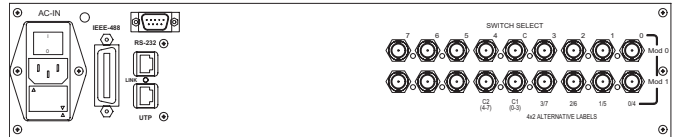

CXAR/16 Rear Panel with IEEE488, RS232 and LAN Control

## CXAR/32 MAINFRAME OR -E EXPANSION CHASSIS

These Chassis control up to 32 switch points in any configuration. LEDs on the front panel show switch and power status. Add Switch Module(s) and a Control Module to complete the system.

- Dimensions:** 19" Rack Mount (483 mm)  
 15" deep (381 mm)  
 3.5" (2 RU) high (89 mm)
- Weight:** 17 lbs (7.7 Kg) max
- AC Power :** 13 Watts max. 110/220 selectable.



CXAR/32 with Pushbutton Manual Control

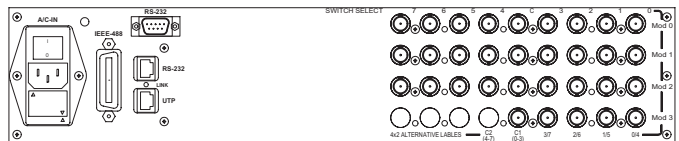

CXAR/32 Rear Panel with IEEE488, RS232 and LAN Control

## CXAR/64 MAINFRAME OR -E EXPANSION CHASSIS

These Chassis control up to 16/1x4 individual switch modules arranged as shown in the drawing. LEDs on the front panel indicate switch and power status. Add 1x4 Switch Modules, a Control Module, and one CL8 Display module for every two 1x4 modules to complete the system.

- Dimensions:** 19" Rack Mount (483 mm)  
 15" deep (381 mm)  
 5.25" (3 RU) high (133 mm)
- Weight:** 20 lbs (9.1 Kg) max
- AC Power :** 22 watts max - 110/220 selectable.

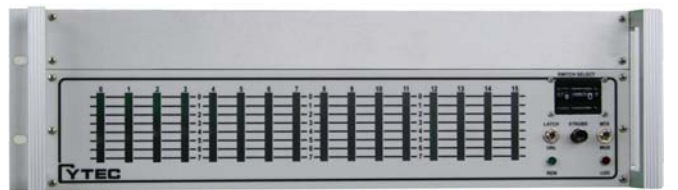

CXAR/64 with Thumbwheel Manual Control

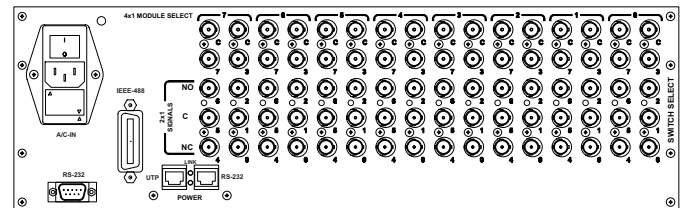

CXAR/64 Rear Panel with IEEE488, RS232 and LAN Control

**FOR TECHNICAL ASSISTANCE, PLEASE CONTACT CYTEC AT 800-346-3117 OR VISIT OUR WEBSITE AT [cytec-ate.com](http://cytec-ate.com)**

## CXAR/128 MAINFRAME OR -E EXPANSION CHASSIS

These Chassis control up to 16 1x8 switch modules arranged as shown in the drawing or combinations of 1x2, 1x4 and 1x8 modules. LEDs on the front panel show Switch and Power Status. Add Switch Modules, a Control Module, and one CL8 Display module for each eight switch points to complete the system.

- Dimensions:** 19" Rack Mount (483 mm)  
 15" deep (381 mm)  
 7" (4 RU) high (178 mm)
- Weight:** 25 lbs (11.4 Kg) max
- AC Power :** 30 watts max. 110/220 selectable



CXAR/128 with MC-2 Keypad Manual Control

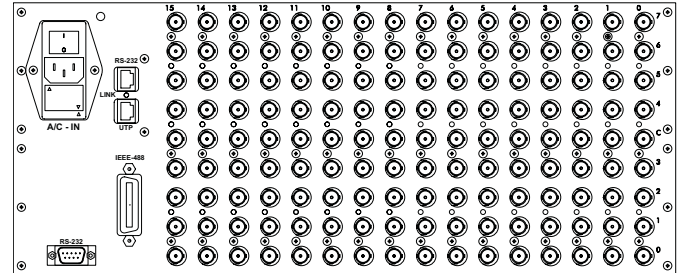

CXAR/128 RearPanel with IEEE-488, RS232 and LAN Control

## CXAR/8(16x1) MAINFRAME OR -E EXPANSION CHASSIS

This Chassis controls up to eight CXS/16x1-GT switch modules arranged as shown in the drawing or combinations of 1x2, 1x4, 1x8 and 1x16 modules. LEDs on the front panel show Switch and Power Status. Add Switch Modules, a Control Module, and one CLE-16 Display module for each 16 switch points to complete the system.

- Dimensions:** 19" Rack Mount (483 mm)  
 15" deep (381 mm)  
 7" (4 RU) high (178 mm)
- Weight:** 30 lbs (13.6 Kg) max
- AC Power :** 40 watts max. 110/220 selectable



CXAR/8(16x1) with MC-2 Keypad Manual Control

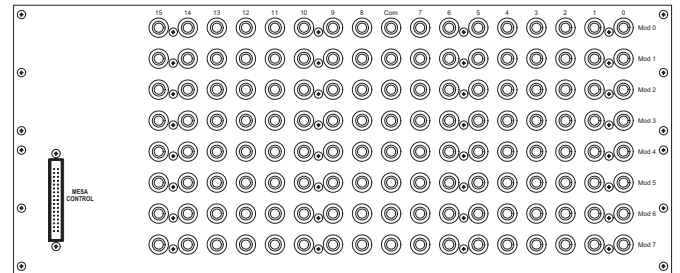

CXAR/8(16x1) RearPanel with IEEE-488, RS232 and LAN

## ALL CHASSIS

- Material:** Gray Anodized extruded or sheet aluminum with a polycarbonate front panel overlay.
- Mounting Hardware:** Rack Mount handles are standard. Flush mount flanges available at no cost.
- Protection:** Selectable AC input fused at: 2 amps 110 VAC, 1 amp 220 VAC.

**FOR TECHNICAL ASSISTANCE, PLEASE CONTACT CYTEC AT  
 800-346-3117 OR VISIT OUR WEBSITE AT [cytec-ate.com](http://cytec-ate.com)**

## CXAR EXPANSION CHASSIS

All CXAR Chassis are available as Expansion Chassis for use with a MESA Control Chassis. This design allows configuration of large or complex systems with one point of control. Using a Mesa Controller and multiple Expansion Chassis has the following advantages:

### Cost Savings

Expansion chassis do not need power supplies or their own Control Modules or Manual Controls, which adds up to cost savings that pay for the Mesa on any system requiring three or more expansion chassis.

### Single Point of Control

You can control up to 32 CXAR chassis, or combinations of different chassis, from a single Mesa Control. This allows control of up to 32 chassis from a single GPIB address, RS232 Port or LAN IP address.

### Remote Location of Multiple Chassis

Expansion Chassis can be located up to 125' from the Mesa, so the switching chassis can be located where needed and still not require a separate control.

### Complex Test Systems

Since any Cytec chassis may be controlled from the Mesa, you can build complicated systems switching a number of different signal types using different Cytec products for each signal type.

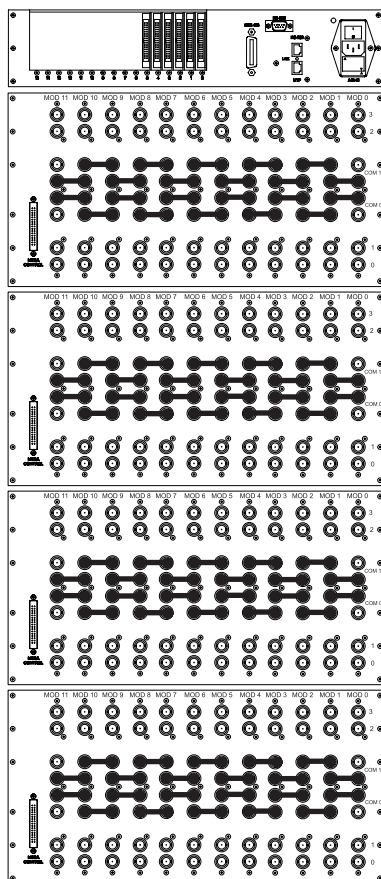

Mesa Example - 256x2 Low Leakage Coax System

## LED INDICATORS / STATUS FEEDBACK

All CXAR Mainframe and Expansion Chassis have LED displays that show state of every relay. These LED indicators are visible on the front panel and correspond to the programmatic address for each relay.

The LEDs provide an invaluable aid for program debugging and troubleshooting. They allow you to verify switch point status instantly simply by watching the system's front panel.

### CXAR/16 and CXAR/32 LED Indicators

On these systems the LEDs are built into the front panel of the chassis and are included in the chassis prices.

### CXAR/64 and CXAR/128 LED Indicators -- CL8 Modules

On these systems the LEDs are provided by a CL8 Display / Driver Modules which must be purchased separately. Each CL8 module provides eight relay drives and LEDs so they are not optional, and one CL8 is required for every eight switch points. The display / driver is also sold separately because some customers use them to drive external relays, or they buy sets of different switch modules for different applications and separate CL8's reduce the total price.

## CXAR CUSTOM CHASSIS

Cytec can easily customize your chassis to fit specific needs with little or no NRE (Non Recurring Engineering) charges. The following examples are only some of the options available. If you don't see what you need feel free to ask us if it can be done. Our engineers will work with you to provide a tailored solution for your specific application.

### Labeling

Cytec's laser etch labeling system allows rapid custom labeling of front or rear panels. Silk screening options or custom poly carbonite overlays are also available for OEM systems.

### Configuration

Cytec can preconfigure your system according to your exact needs. Some examples are listed below:

- Build large multiplexers using bus bars or interconnecting tree switches in series.
  - Build large group switches with parallel drive wiring.
  - Custom configured modules.
  - Customized connectors, false rear panels or patch panels.
- Don't see it? Just ask!

### Chassis Dimensions or Mounting Options

We can build chassis with different dimensions or mounting options, including reverse mounting the chassis to get the connector out of the front, add connectors to the front panel or flush mount the chassis for tight rack enclosures.

### Custom components

Need a system with non-Cytec components added to get the exact performance you need? Just let us know what you want to accomplish. We can add splitters, amps, couplers and other RF components to give you exactly what you need.

# CXR REED OR ARMATURE RELAY SWITCH MODULES

These switch modules use reed or armature relays interconnected by characteristic impedance striplines and are completely bi-directional. They are an excellent, cost effective choice for applications below 200 MHz. BNC connectors are standard. Bus bars are available to build larger configurations, but lower bandpass. These modules provide the best solution for lower frequency applications that require coaxial connections.

## CXR/2x1-1S or -2S ( Form A )

This module switches a common port between A, B or OFF positions as shown in Fig. 1. Module uses single or two pole, Type S reed relays. Bandpass is 400 MHz (-3 dB). Crosstalk is -60 dB at 5 MHz.

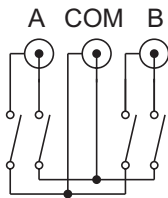

Fig. 1

## CXR/2x1-2C ( Form C )

A two pole 2x1, Form C configuration as shown in Fig. 4 which allow one input to be switched to two outputs (A or B). Available with BNC or Twin BNC connectors, and uses Type A, Armature relays. This module defaults to a normally closed position when off. Bandpass of 200 MHz (differential into 100 ohms).

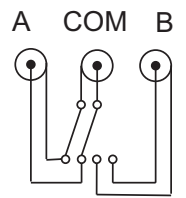

Fig. 4

## CXR/8x1-1T-BNC

This module has single pole Type T relays which terminate the inputs to the required impedance as shown in Fig. 2. Energizing the selected relay removes the termination from the input and closes the circuit.

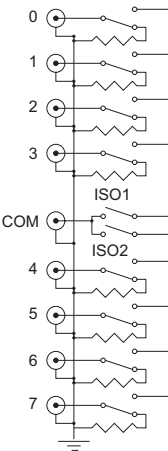

Fig. 2

## CXR/8x1-1HT

This is a High Isolation Module with relays which terminate the inputs to the required impedance, and they have additional isolation relays as shown in Fig. 5 which decrease the crosstalk between channels by 20dB. Energizing a relay removes the terminating impedance and completes the selected path.

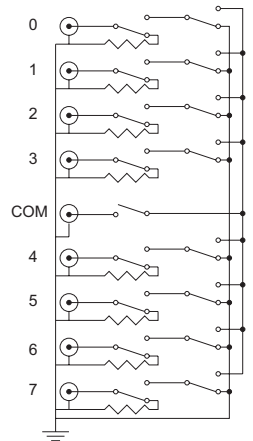

Fig. 5

## CXR/8x1-1S-BNC

This is the same configuration but without termination.

## CXR/4x1-1T-BNC

This is the same terminated configuration but with only four relays.

## CXR/4x1-1S-BNC

This is the same configuration with only four relays and without terminations.

## CXR/8x1-2A

This is an 8x1 two pole configuration as shown in Fig. 3. Ideal for switching balanced line 100 ohm differential pairs. It is available with isolated BNC's or Twin BNC connectors (Twinax), and uses Type 2A relays.

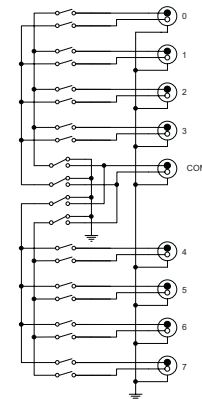

Fig. 3

## CXR/8x1-1HS

Has the same high isolation characteristics as the model -1HT but without input terminations.

## CXR/4x1-1HT

Has the same characteristics and configuration but with only four relays.

## CXR/4x1-1HS

Is the same as the model -1HT but without termination.

## HIGH FREQUENCY SPECIFICATIONS

Type	Bandpass MHz	Isolation @ 100 MHz
CXR/8x1-1 and 4x1-1	300	60dB
CXR/8x1-T and 4x1IT	300	65dB
CXR/8x1-HS and 8x1-HC	250	70dB
CXR/4x1-HS and 4x1-HT	300	70dB
CXR/8x1-2A and 4x1-2A	200	45dB

## SWITCH CHARACTERISTICS

	Type S	Type T	Type 2A
Switch Voltage	200V	200V	110 V
Switch Current	0.5A	0.25A	1.0A
Breakdown Voltage	400V	200V	750V
Operating Time	1ms	1ms	3 ms
Life Expectancy	10 <sup>8</sup> *	10 <sup>8</sup>	2x10 <sup>5</sup> *
Contact Rating	10VA	3VA	60VA

\* @ 900 MHz 10 Watts

# CXR-G SWITCH MODULES

These modules are designed with Type G coaxial relays arranged in a tree configuration as shown in Figs. 6 through 8 with on board logic that selects the appropriate relays to connect the selected input to the common. Only one input can be switched to one output, and in the unenergized state or input #0 is connected to the common, except the terminated modules which have an open condition. All -G Modules are available with 50 or 75 ohm characteristic impedance. 50 Ohm modules are available with SMA or BNC connectors. 75 Ohm modules have BNC's only. Combinations of these modules can be assembled to form larger multiplexers or matrices.

## CXR/2x1-G ( Form C )

This module switches the common to one of two inputs as shown in Fig. 6. In the unenergized position, the common is connected to input A.

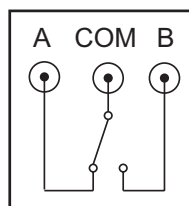

Fig. 6

## CXR/2x1-GT ( Form A )

This module is a version of the CXR/2x1-G module that has the unused A/B connection terminated into 50 or 75 ohm resistors as shown in Fig 9. This module allows an off state with both inputs terminated.

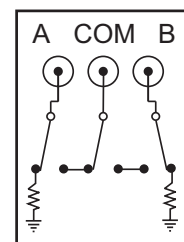

Fig. 9

## CXR/8x1-G

Is a bidirectional 8x1 configuration as shown in Fig. 7. The module is normally closed to connector 0 when off.

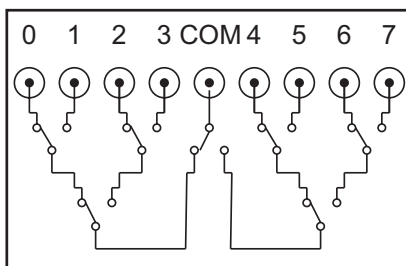

Fig. 7

## CXR/8x1-GT TERMINATED MODULE

This module switches any one of eight 50 or 75 ohm terminated coaxial inputs to one output as shown in Fig. 10. Switching any input removes the termination from that input and connects it to the common.

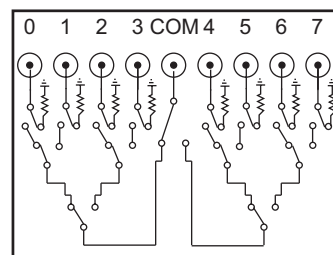

Fig. 10

## CXR/4x1-G

This module is a bidirectional 4x1 configuration using connectors 0 thru 3 of Fig. 7. It is available with the same connectors and has the same bandpass and isolation as the 8x1 module.

## CXR/4x1-GT TERMINATED MODULE

Switches any one of four coaxial inputs to common using inputs 0 thru 3 of Fig. 10. It is available with the same connectors and has the same bandpass and isolation as the 8x1 module.

## CXR/4x2-G

This module switches any two of 4 coaxial ports to the two commons as shown in Fig. 8.

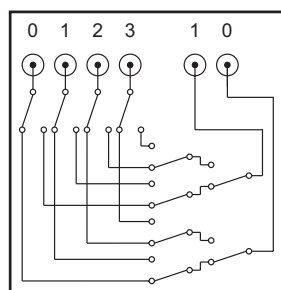

Fig. 8

## RELAY SPECIFICATIONS

Switched Power	10 Watts ( 40 dBm)
Carry Power	20 Watts
Termination rating	5 Watts
Operating Time	3 ms
Life Expectancy*	3x10 <sup>5</sup>
Max Voltage	30 VDC

\* @ 900 MHz 10 Watts

	Insertion Loss			Isolation			VSWR
	.5 GHz	1 GHz	-3 dB Point	.5 GHz	1 GHz	2 GHz	
CXR/2x1-G-50-SMA or BNC	0.25 dB	.5 dB	2.0 GHz	-65 dB	-55 dB	-40 dB	<1.25:1 @ 1 GHz
CXR/2x1-G-75-BNC	0.6 dB	2.0 dB	1.3 GHz	-65 dB	-50 dB	NA	<1.25:1 @ 750 MHz
CXR/2x1-GT-50-SMA or BNC	0.4 dB	1.4 dB	1.6 GHz	-70 dB	-60 dB	-50 dB	<1.3:1 @ 1 GHz
CXR/2x1-GT-75-BNC	0.8 dB	2.8 dB	1.1 GHz	-70 dB	-55 dB	NA	<1.3:1 @ 900 MHz
CXR/8x1-G-50 -SMA or BNC	0.5 dB	.9 dB	2.3 dB	-70 db	-65 dB	-50 dB	<1.3:1 @ 1 GHz
CXR/8x1-G-75-BNC	1.2 dB	2.5 dB	1.2 GHz	-65 dB	-50 dB	NA	<1.3:1 @ 750 MHz
CXR/8x1-GT-50-SMA or BNC	0.7 dB	1.4 dB	1.5 GHz	-70 db	-65 dB	-50 dB	<1.3:1 @ 1 GHz
CXR/8x1-GT-75-BNC	1.3 dB	3.0 dB	1.0 GHz	-65 dB	-50 dB	NA	<1.3:1 @ 750 MHz
CXR/4x2-G-50-SMA	1.4 dB	2.4 dB	1.2 GHz	-60 dB	-50 dB	NA	<1.3:1 @ 650 MHz
CXR/4x2-G-75-BNC	1.5 dB	3.5 dB	800 MHz	-60 dB	-45 dB	NA	<1.3:1 @ 500 MHz

## CXR LOW LEAKAGE MODULE

This module is designed with for applications where you need to measure extremely low currents or extremely high resistance. The module is arranged as two 4x1 sections that can be wired as an 8x1, 4x2 or many other configurations. A schematical representation of the module is shown in Fig. 11. Many jumpering options allow this module to be grounded or ungrounded or used with a driven guard circuit to improve speed and accuracy. Above board wiring with coax cables keeps noise and charge times to a minimum. Combinations of these modules can be assembled to form larger multiplexers or matrices. Contact a Cytec specialist to discuss which options are best for your specific application.

### CXR/2(4x1)-LL-BNC or TRX SWITCH MODULE

Dual 4x1 low leakage modules can be used to measure currents down to 50 femtoamps ( $5 \times 10^{-14}$  amps), or resistances up to teraohms ( $10 \times 10^{12}$ ). Maximum switched voltage of 1500 VAC. It is available with either BNC or Triax connectors.

The module may be used in Cytec CXAR Series 16, 32, or 10.5" high 128 channel chassis. Bus bars are available to form larger multiplexers or matrices. Custom configurations are available.

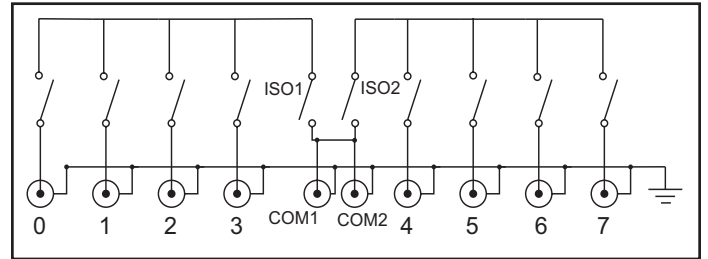

Fig. 11

## CXS SOLID STATE CABLE TV or MODEM MODULE

These modules are designed for 75 ohm applications operating at frequencies from DC to 1 GHz, making them perfect for cable TV and cable modem applications. Terminated inputs and outputs guarantee impedance matching on unused channels. Insertion loss is flat within 1 dB over the range of 1 MHz to 1000 MHz.

### CXS/8x1-GT-75 Switch Module

This switch is identical in function to the electro-mechanical relay version of our 75 ohm 1x8 mux, but the use of solid state components makes it operate with very good specifications over the frequencies of 1 to 900 MHz commonly used for cable modems and cable TV. Available with BNC or F type connectors. This switch module fits in any standard Cytec CXAR Series chassis.

	100 MHz	500 MHz	1000 MHz
INSERTION LOSS	-2.0 dB	-2.5 dB	-3 dB
ISOLATION	-60 dB	-55 dB	-50 dB
SWITCHED POWER	24 dBm (0.25 watts)		
SWITCHING SPEED	< 1 ms		
LIFE EXPECTANCY	$1 \times 10^8$ operations		

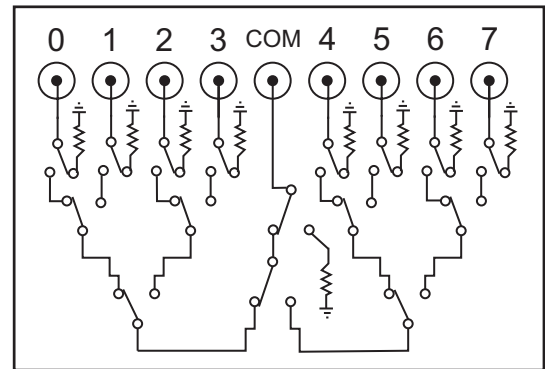

Fig. 12

### CXS/16x1-GT-75-F Switch Module

This is a 16x1 version of the solid state switch with F connectors as shown in Fig. 13. The specifications are the same as shown above.

Up to 8 of these modules may be installed into a standard Cytec CXAR/8(16x1) Mainframe or Expansion Chassis.

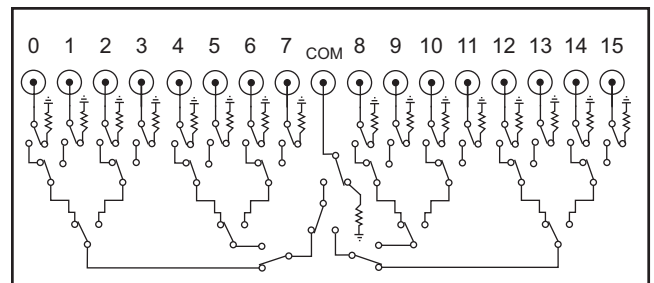

Fig. 13

## CONTROL MODULES

### IF-5C IEEE488/RS232 16 and 32 Channel Control

This Module has both the IEEE488 (Talk/Listen) and the RS232 features detailed in Applications Bulletin AP-5. This combination module is used on all 16 or 32 channel chassis.

### IF-5 IEEE488/RS232 64 and 128 Channel Control

This Module has both the IEEE488 (Talk/Listen) and the RS232 features detailed in Applications Bulletin AP-5. This combination module is used on all 64 or 128 channel chassis.

### IF-6 LAN INTERFACE

This Module uses TCP/IP to allow control from a Local Area Network as described in AP-5. It is available as an option on any unit with RS232 Control.

## MANUAL CONTROL OPTION

Manual Controls are available for all mainframe chassis.

**CXAR/16** and **CTC/16** chassis can be purchased with optional 16 channel pushbutton manual control PB/16. CXAR/32, CTC/32 and CTA/32 mainframes use PB/32 thirty-two channel pushbuttons.

**CXAR/64** and **CTC/64** mainframes are built with thumbwheel manual controls MC/64-TW. CXAR/128, CTA/128 and CTC/64 chassis can be built with keypad manual controls MC-2.

## PATCH PANELS

Patch Panels are available to convert the standard switch module coaxial connectors (typically BNCs or SMA) to a type specified by the customer, including Triax, Dual BNCs, and Twin BNCs. Please contact Cytec with your specific requirement.

## CYTEC SWITCH MANAGER SOFTWARE



The Cytec Switch Manager provides a GUI interface for controlling matrices and multiplexers via remote computer. The software includes an intuitive graphical interface, security implementation, built in test functionality, multiple device control, switchpoint memory, as well as many other useful features. You can download the Switch Manager free of charge from our website.

Available for Windows, Linux, Mac OS, or any other Java enabled platform

## SOFTWARE

Free drivers and/or sample programs are available for the most commonly available application programming languages.

## WARRANTY

CYTEC Corp. warrants that all products are free from defects in material or workmanship for a period of five years.

## CXBS COAXIAL BUS STRIPS

The Bus Strips are used to connect between CXR Coaxial Switch Modules and are designed for maximum bandpass and minimum stub length. They are available to interconnect up to 16 modules. Can not be used with **Type G** or **Type 2A** Modules.

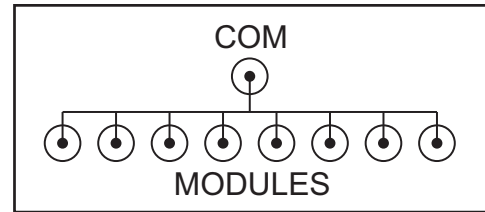

Fig. 14

## CX/G AMPLIFIER

This amplifier has one BNC input and up to 3 BNC outputs. It can be used to restore signal levels or as a Signal Distributor to 3 Devices, as shown in Fig. 15. It has a **Bandpass** of **DC to 200 MHz** with a 4 volt p/p output and preset gains from 1 to 16. Impedances on both inputs and outputs can be preset for impedance matching.

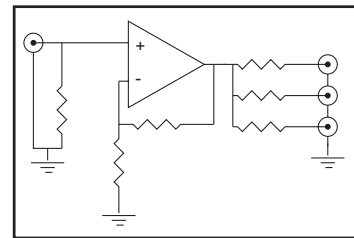

Fig. 15

## CXR/1x8-PD POWER DIVIDER MODULE

This module is a 1x8 power divider intended for use between 5 MHz and 500 MHz. The module has a unity gain amplifier so that all 8 outputs maintain the signal input level (+/- 2 dB) in the given frequency range. The module is available with **SMA** or **BNC** connectors. A schematic is shown in Fig. 16.

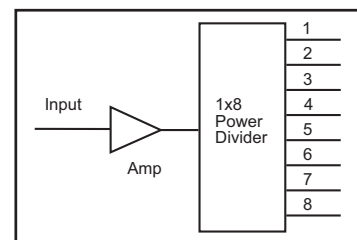

Fig. 16

## CUSTOM SYSTEMS ARE AVAILABLE.

**DON'T SEE WHAT YOU NEED?  
PLEASE CALL FOR MORE OPTIONS.**

**FOR TECHNICAL ASSISTANCE, PLEASE CONTACT CYTEC AT  
800-346-3117 OR VISIT OUR WEBSITE AT [cytec-ate.com](http://cytec-ate.com)**